

Relay 2.0

CARPET TILES

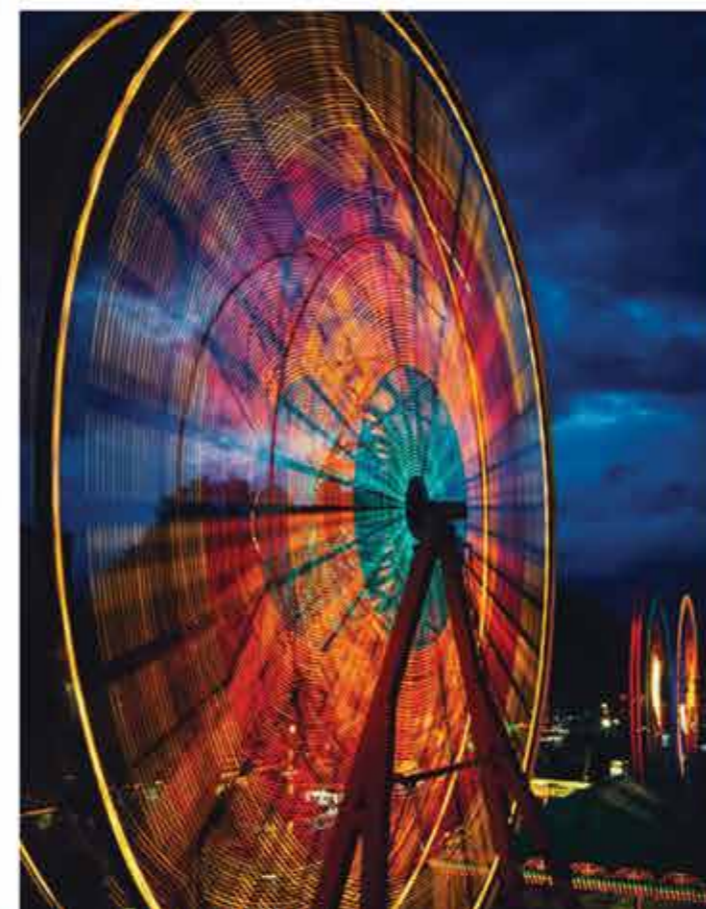

WELSPUN
FLOORING



GO BOLD GO RELAY



Bold, full of life and energy.

That was our inspiration for our Relay Collection.

Bright colours, bold lines all of which shout activity and energy.

Ideal for your office spaces which radiate a sense of dynamism.





ARTICLE CODE: **CT001148** | DESIGN NAME: **SHIFT** | COLOR: **SEA WATER**
ARTICLE CODE: **CT000084** | DESIGN NAME: **PASSAGE** | COLOR: **ELECTRIC BLUE**

PATTERN USED



COLORWAYS



ARTICLE CODE: **CT000076** | DESIGN NAME: **SHIFT** | COLOR: **ORANGE**
ARTICLE CODE: **CT000085** | DESIGN NAME: **PASSAGE** | COLOR: **ORANGE**
ARTICLE CODE: **CT000173** | DESIGN NAME: **WAVE** | COLOR: **IRON**

PATTERN USED

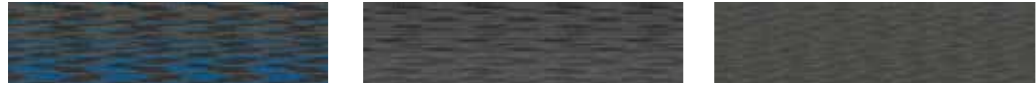

COLORWAYS

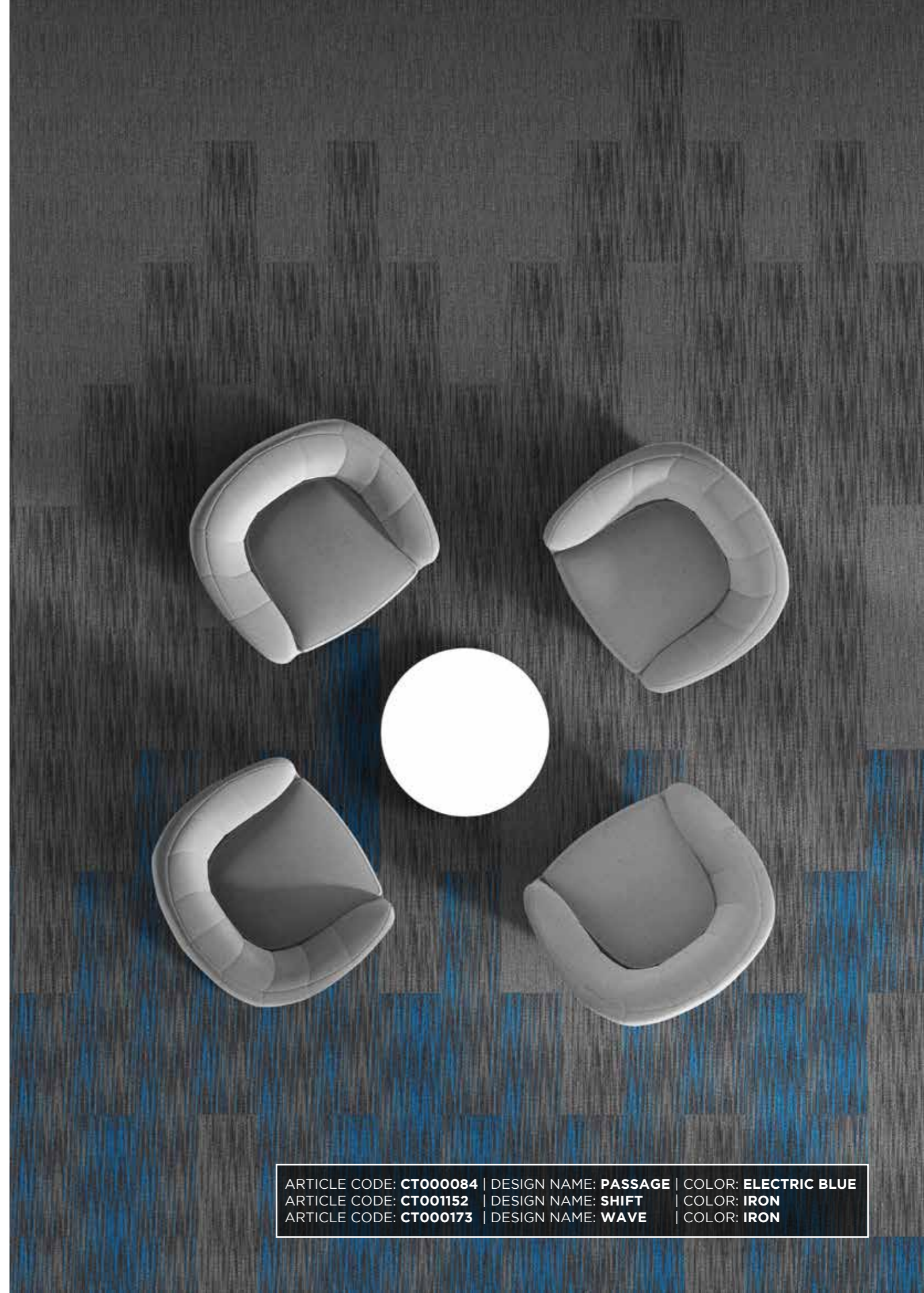
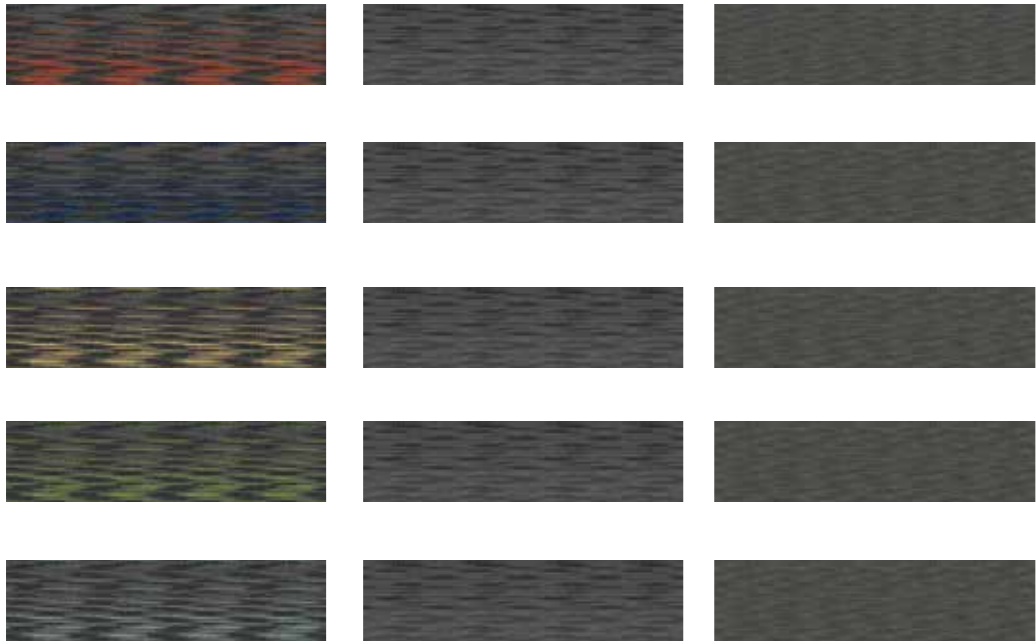

ARTICLE CODE: **CT000084** | DESIGN NAME: **PASSAGE** | COLOR: **ELECTRIC BLUE**
ARTICLE CODE: **CT001152** | DESIGN NAME: **SHIFT** | COLOR: **IRON**
ARTICLE CODE: **CT000173** | DESIGN NAME: **WAVE** | COLOR: **IRON**

PATTERN USED

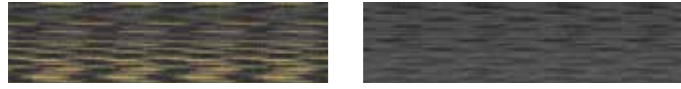

COLORWAYS

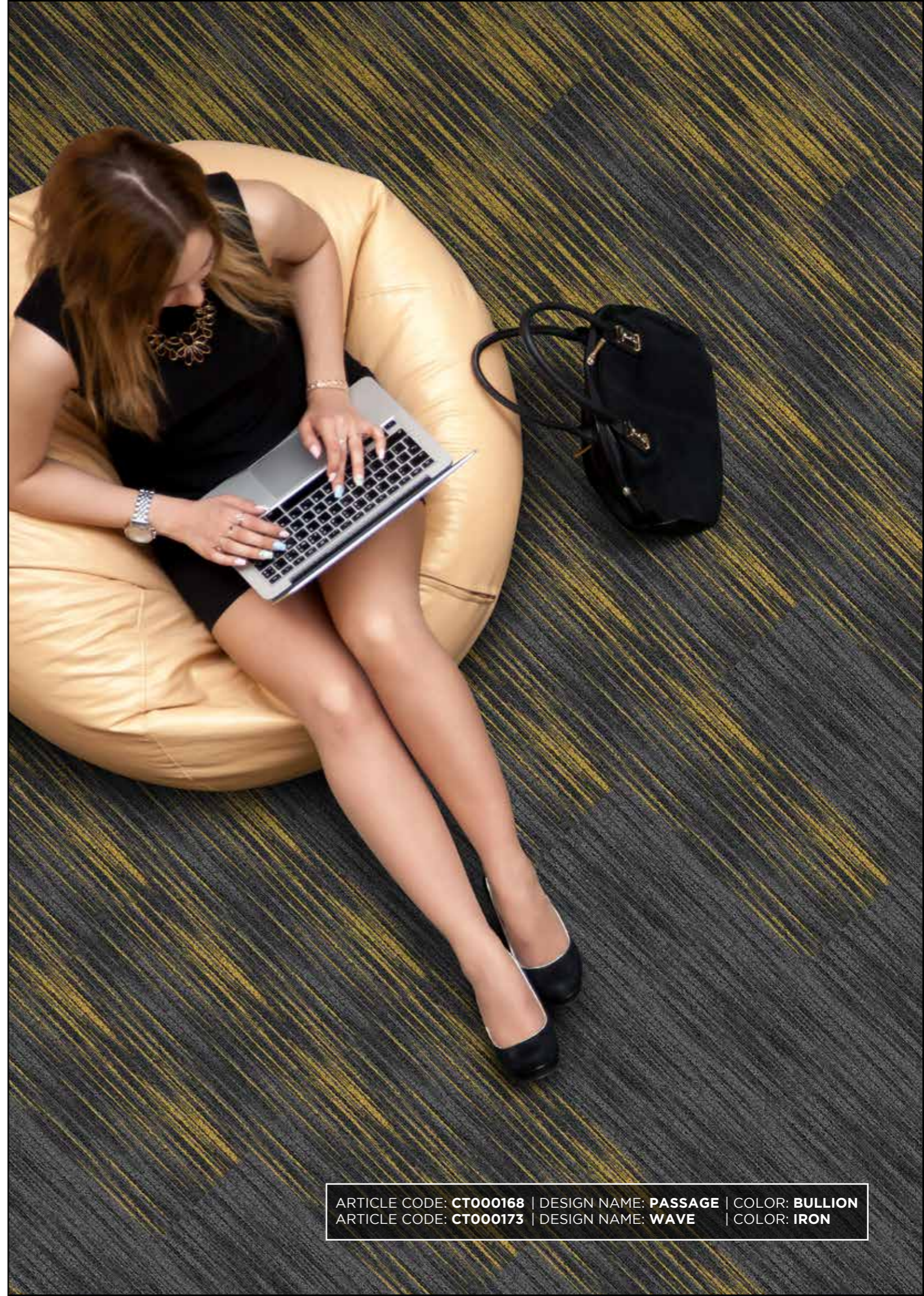
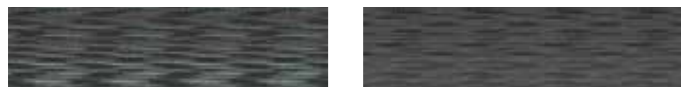
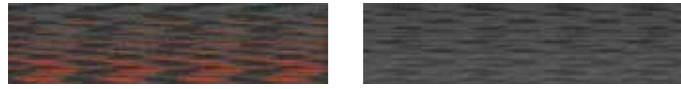

ARTICLE CODE: **CT000168** | DESIGN NAME: **PASSAGE** | COLOR: **BULLION**
ARTICLE CODE: **CT000173** | DESIGN NAME: **WAVE** | COLOR: **IRON**

PATTERN USED



COLORWAYS



ARTICLE CODE: **CT001148** | DESIGN NAME: **SHIFT** | COLOR: **SEA WATER**
ARTICLE CODE: **CT001153** | DESIGN NAME: **SHIFT** | COLOR: **MIST**
ARTICLE CODE: **CT000171** | DESIGN NAME: **PASSAGE** | COLOR: **MIST**

PATTERN USED



COLORWAYS

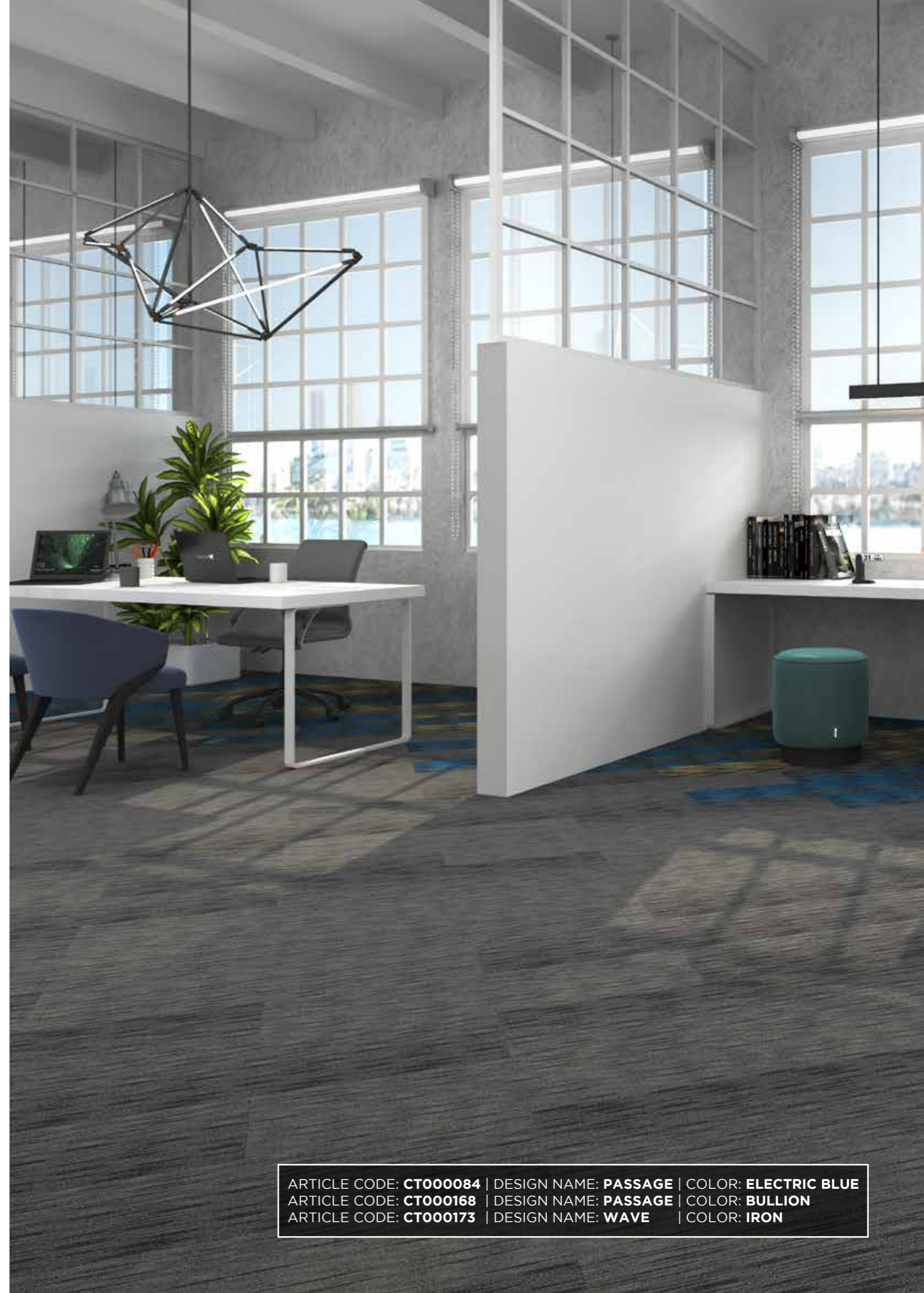
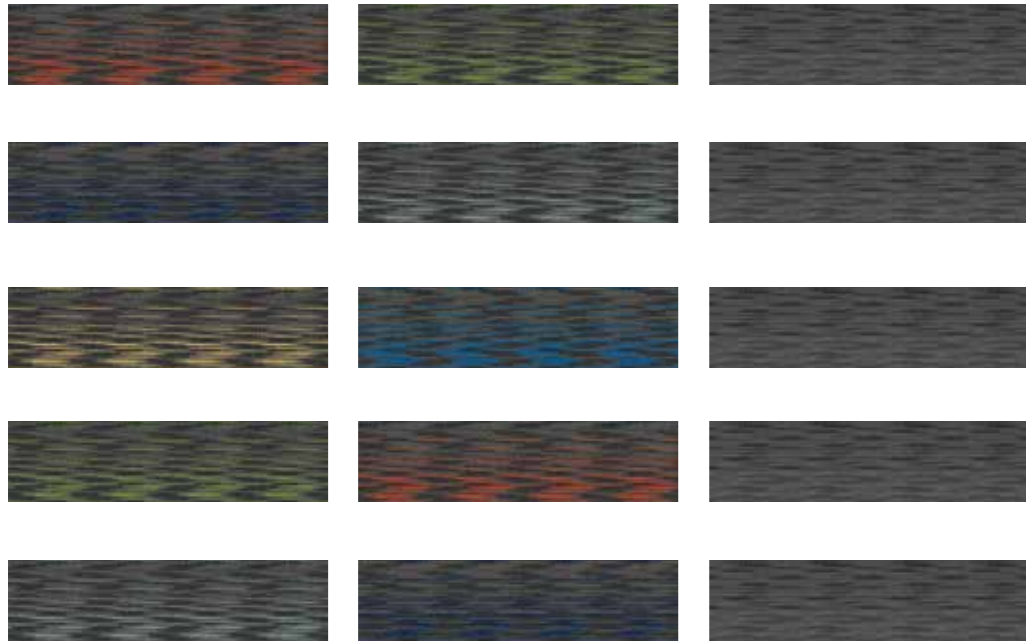

ARTICLE CODE: **CT000084** | DESIGN NAME: **PASSAGE** | COLOR: **ELECTRIC BLUE**
ARTICLE CODE: **CT000168** | DESIGN NAME: **PASSAGE** | COLOR: **BULLION**
ARTICLE CODE: **CT000173** | DESIGN NAME: **WAVE** | COLOR: **IRON**

PATTERN USED

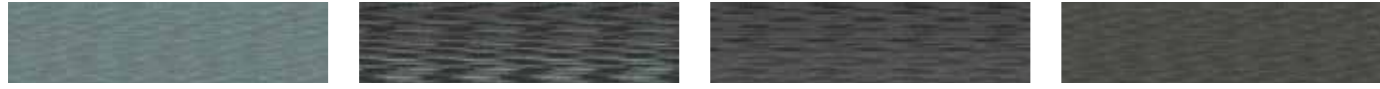

COLORWAYS

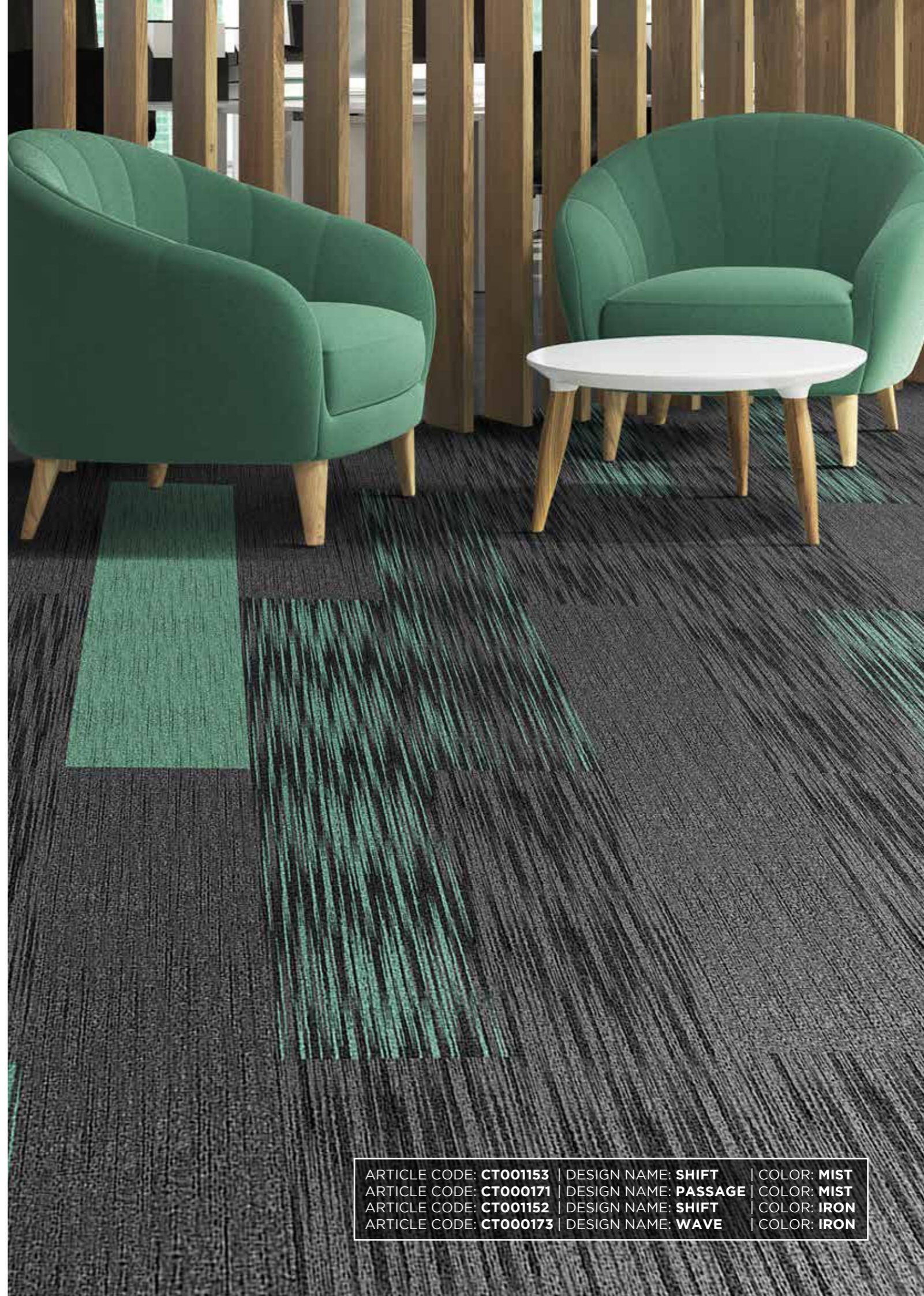
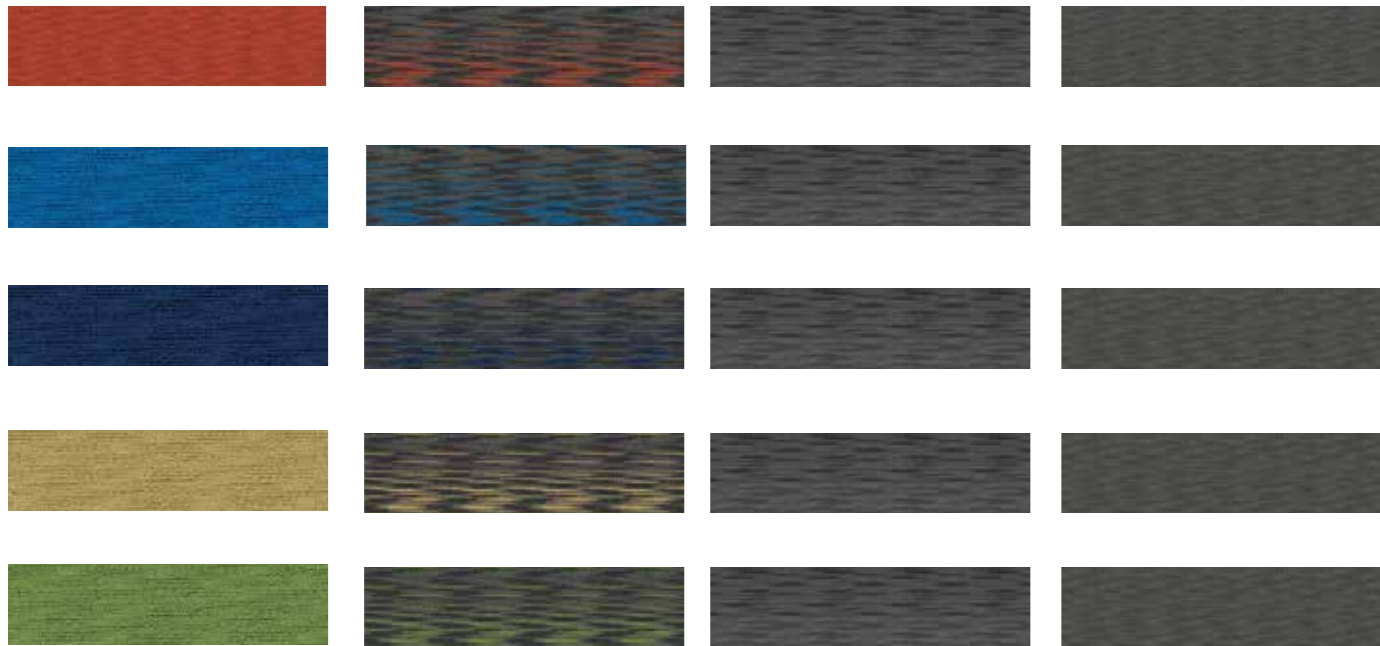

ARTICLE CODE: CT001153	DESIGN NAME: SHIFT	COLOR: MIST
ARTICLE CODE: CT000171	DESIGN NAME: PASSAGE	COLOR: MIST
ARTICLE CODE: CT001152	DESIGN NAME: SHIFT	COLOR: IRON
ARTICLE CODE: CT000173	DESIGN NAME: WAVE	COLOR: IRON

LAYOUT PATTERNS

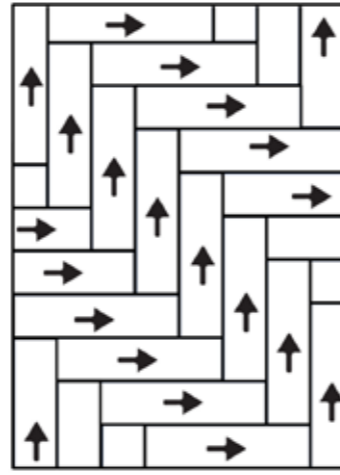

CHEVRON PLANK

LAYOUT PATTERNS

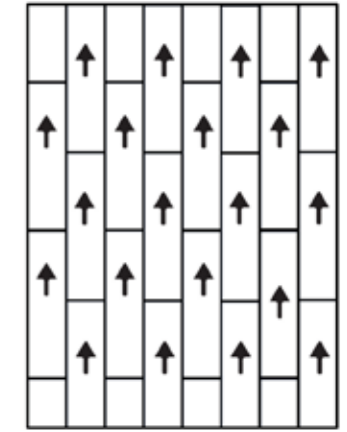

BRICK PLANK

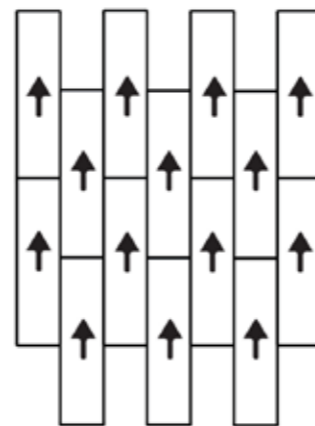
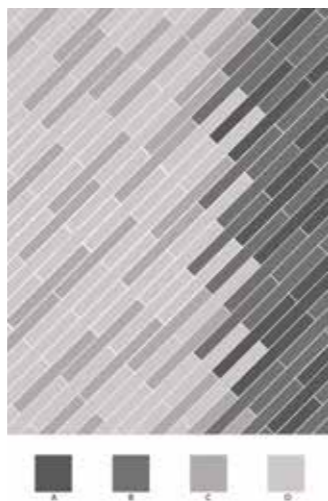

ASHLAR PLANK

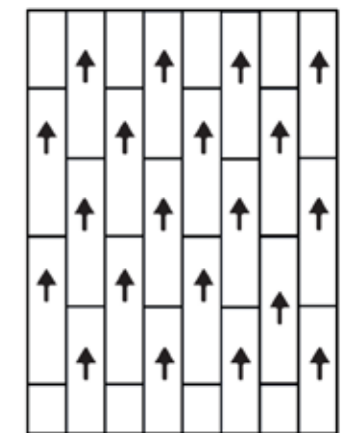
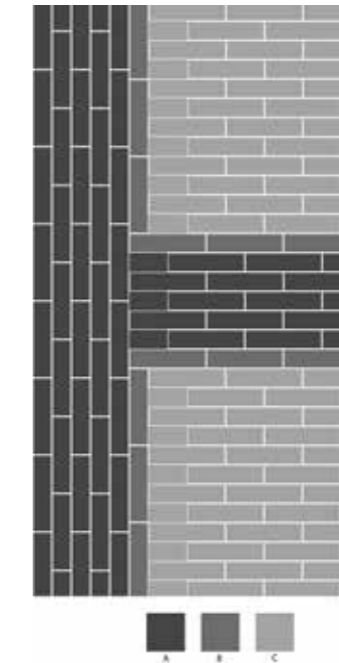

BRICK PLANK

LAYOUT PATTERNS

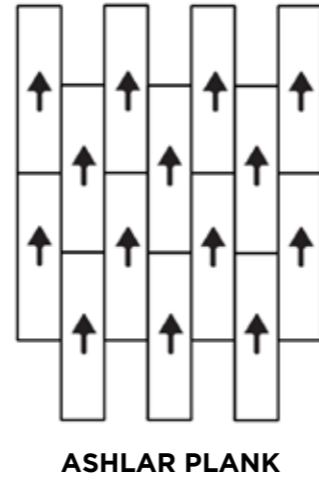
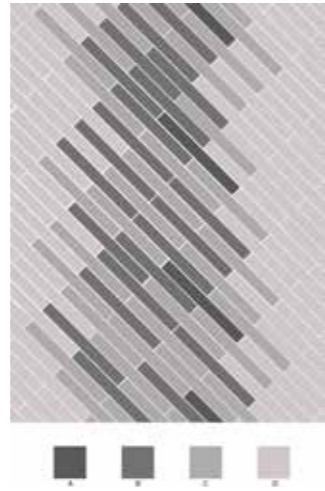

LAYOUT PATTERNS

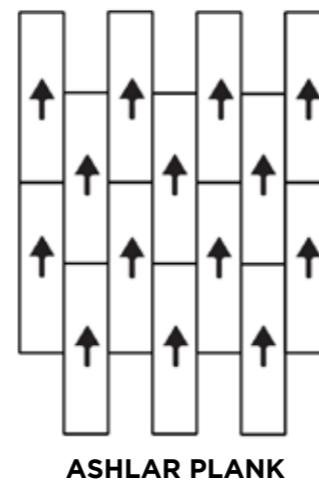
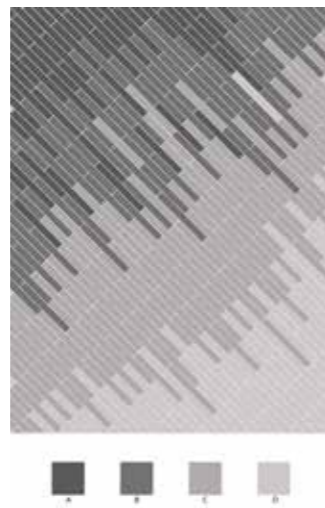
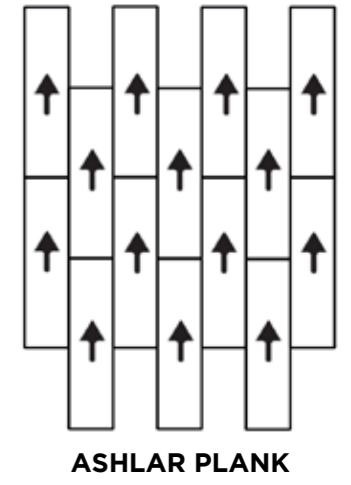
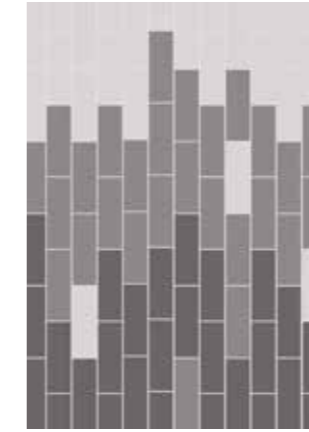
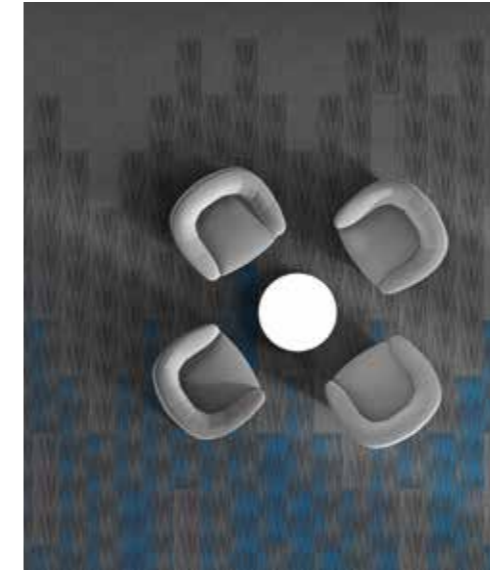

SHIFT

RANGE



PLANK | AC: CT000076

BLUE



PLANK | AC: CT000075

DIVE



PLANK | AC: CT001148

GOLD



PLANK | AC: CT001149

LIME



PLANK | AC: CT001151

MIST



PLANK | AC: CT001153

ROCK

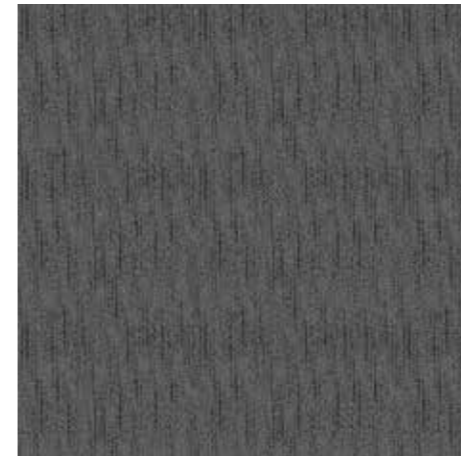

PLANK | AC: CT0001152

SHIFT

PASSAGE

DIFFUSE



PLANK | AC: CT000085

TRACK

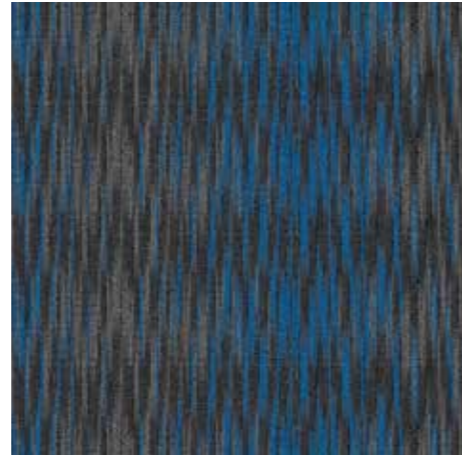

PLANK | AC: CT000084

PASSAGE

WIRE



PLANK | AC: CT000167

ROUTE



PLANK | AC: CT000168

BLAZE

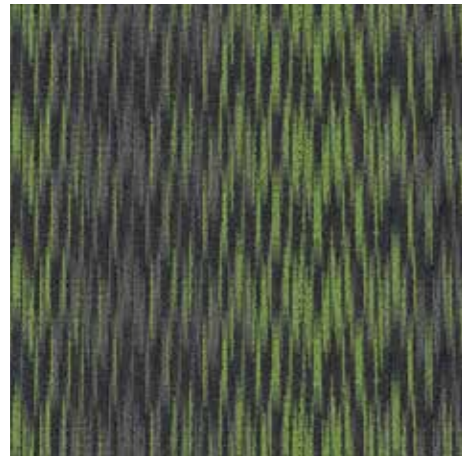

PLANK | AC: CT000170

COURSE

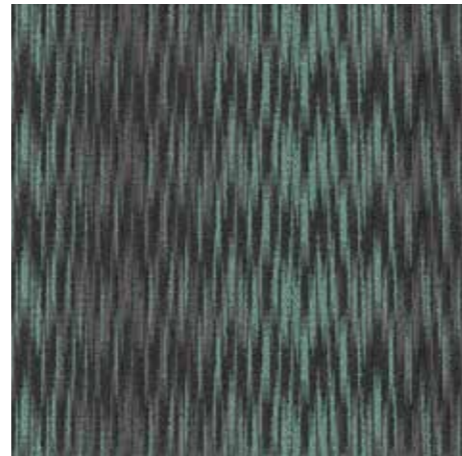

PLANK | AC: CT000171

WAVE

CABLE

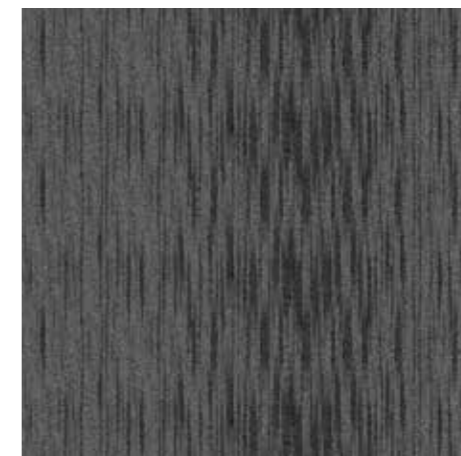

PLANK | AC: CT000173

PRODUCT SPECIFICATION

Machine	1/12 Infinity
Filament	69
Yarn Details	100% Nylon Type-6
Size in centimeter	25x100cm
GSM*	594
Finished pile thickness*	Up to 3 mm
Density	Min. 5800
Total thickness*	4-5 mm
Tufted pile wt OZ (Sq Yard)*	18
Dye method	Solution Dyed
Fiber Type	Nylon
Stitch 10 cm	43
Backing Material	PVC
PVC GSM	2000
No of pcs per box	20
Sqft/box	53.8
Sqm/box	5
Shape (Plank or tile)	Plank
SPI	11
Soil Release Technology	Perma Seal Env
GSA Stain Release Rating Foot Traffic	Pass
Recommendation TARR	Severe
*Tolerance (+-)%	5%

India's First Antiviral Flooring*

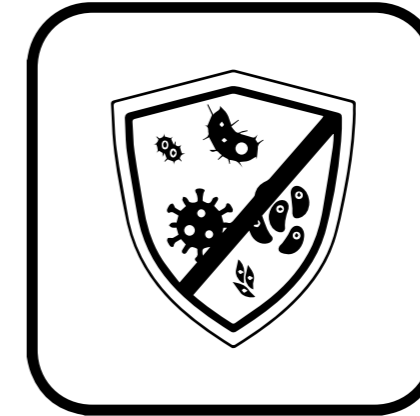

HealthyFloor™

Anti Bacterial

Anti Microbial

Grout Free Flooring

Anti Slip

*Test ed by **Biotech Labs, Mumbai**

WELSPUN CARPET TILES ADVANTAGES

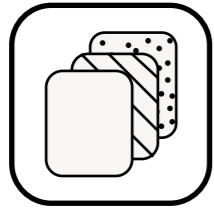

Multiple Design Possibilities

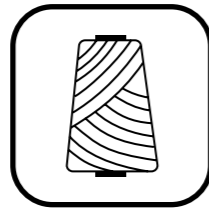

Solution Dyed Tufted Product



Ideal For Heavy Foot Traffic

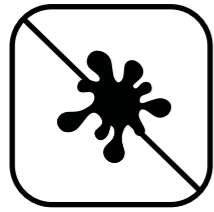

Stain Protect



Easy To Maintain



Easy To Install



Offers Sound Insulation



Reduces Wastage During Installation

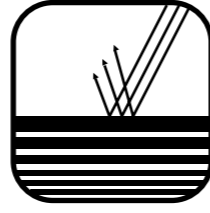

Fade Resistant



Made in India



40% Less Environmental Footprint

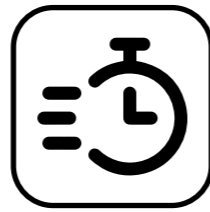

Less Lead Time

TRADEMARKS & TECHNOLOGIES

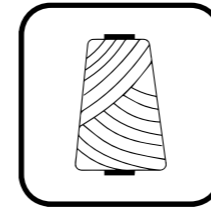

NY6+™

For colors those don't fade out, Welspun Floorings Ny6+™ is made up of a highly resilient fiber that is known for its superior color retention, strength, stain and fade resistance. With all this, your floor always retains its beauty come what may.



Welspun Ecolite™

Welspun Ecolite™ backing is made up of lightweight PVC that not only reduces the overall weight significantly but ensures a 40% less environment footprint than traditional carpets. Despite that, this backing retains the highest performance standards.



Now also available with **HealthyFloor™** (Optional)

We also have carpet tiles options with **antiviral property**. Tested and certified by ResInnova labs, we are India's first antiviral carpet tiles. It kills 99.68 % human corona virus because of a special coating of silver iron and titanium oxide. We make healthy floors.



Comfortile™ (Optional)

With Comfortile™ backing, our tiles come with a customized felt-back that not only offers great underfoot comfort but also sound absorption. Comfortile™ provides extra levels of protection and support for high levels of acoustic and ergonomic support.

CERTIFICATIONS

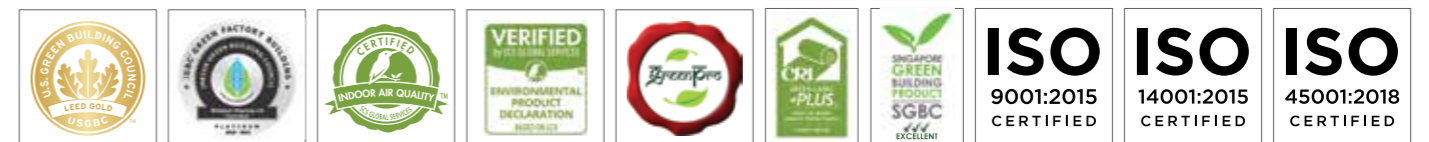



WELSPUN FLOORING

To transform your flooring, just get in touch with us:

Address:

Welspun Global Brands Ltd,
Survey No 190, Chandanvelly, Near Hythabad, Shabad Mandal,
Ranga Reddy District, Telangana 501503, India

Contact us:

☎ 1800 120 1161

✉ contact_flooring@welspun.com

www.welspunflooring.com